

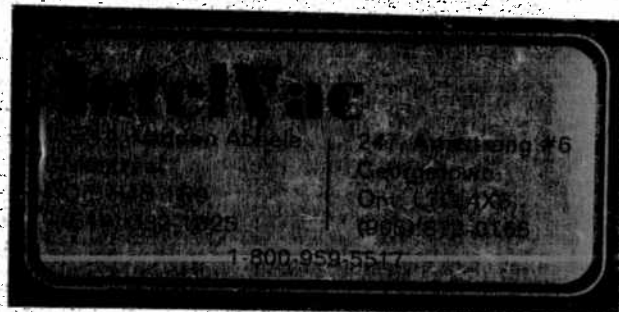

TECHNIQUES DU VIDE  
HIGH VACUUM TECHNOLOGY  
HOCHVAKUUMTECHNIK



notice technique  
instruction manual  
technische beschreibung

POMPES PRIMAIRES MECANIQUES  
MECHANICAL FOREPUMPS

Type / Type : 2033 H - 2063 H



A L C A T E L  
Division Vide et Mécanique  
55, rue Edgar Quinet  
92240 MALAKOFF

---

Tél. : 16.1.40.92.30.00  
Télex : ALCANUC 632 033 F.

TEXTE FRANCAIS . . . . .	Page 1
ENGLISH TEXT . . . . .	Page 39

POMPES PRIMAIRES MECANIQUES  
MECHANICAL FOREPUMPS

Type / Type : 2033 H - 2063 H

Edition : 03.1987.

Notice - Référence )  
Manual - Part Number ) 65094

MECHANICAL FOREPUMPS

TYPES 2033 H - 2063 H

CONTENTS

	pages
NOTES . . . . .	41
 <u>CHAPTER 1 - INTRODUCTION</u>	
1.1. - Description of product . . . . .	42
1.2. - Electrical characteristics . . . . .	43
1.3. - Technical specifications . . . . .	43
1.4. - Size . . . . .	
 <u>CHAPTER 2. - OPERATING PRINCIPLE</u>	
2.1. - Single stage mechanical pump . . . . .	44
2.2. - Two-stages pump . . . . .	45
2.3. - Oil . . . . .	45
2.4. - Lubrication . . . . .	45
2.5. - Antisuckback . . . . .	45
2.6. - Noise limiter . . . . .	46
2.7. - Roll of the sealed department . . . . .	47
2.8. - . . . . .	
 <u>CHAPTER 3. - MOUNTING AND INSTALLATION</u>	
3.1. - Unpacking . . . . .	48
3.2. - Storage . . . . .	48
3.3. - Choosing the oil . . . . .	49
3.31 - Why correct oil is important . . . . .	49
3.32 - Recommended oils . . . . .	49
3.4. - Set up . . . . .	50
3.41 - Filling main chamber with oil . . . . .	50
3.42 - Filling intermediate chamber with oil . . . . .	50
3.43 - Mechanical connections . . . . .	50
3.44 - Accessory table . . . . .	51
3.45 - Electrical connection . . . . .	51
 <u>CHAPTER 4. - OPERATING AND MAINTENANCE</u>	
4.1. - Start up . . . . .	51
4.11 - Temperatures . . . . .	51
4.12 - Starting after disassembly and reassembly . . . . .	51
4.13 - Normal startup . . . . .	51
4.14 - Special cases . . . . .	53
4.2. - Using noise limiter . . . . .	53
4.3. - High-pressure pumping . . . . .	54
4.4. - Using intermediate chamber . . . . .	55
4.41 - Discharge pressure above atm.pressure . . . . .	55
4.42 - Discharge pressure below atm.pressure . . . . .	56
4.43 - Notes . . . . .	56
4.5. - Changing from one type of oil to another . . . . .	57
4.6. - Oil level - Draining . . . . .	57
4.7. - Flushing . . . . .	58

	pages
<b>CHAPTER 5. DISASSEMBLY - CLEANING AND REASSEMBLY</b> . . . . .	<b>59</b>
5.1. - Removing motor . . . . .	59
5.2. - Disassembling moving parts . . . . .	59
5.21 - Motor . . . . .	59
5.22 - Removing oil casing . . . . .	60
5.23 - Disassembling pumps 2033 H - 2063 H . . . . .	60
5.3. - Cleaning metal parts . . . . .	62
5.4. - Replacing seals and other elastomer parts . . . . .	62
5.41 - O-rings . . . . .	62
5.42 - Shaft seals . . . . .	62
5.5. - Reassembly . . . . .	63
5.51 - General instructions . . . . .	63
5.52 - Assembling moving parts . . . . .	64
5.53 - Assembling oil pump . . . . .	64
5.54 - Motor coupling . . . . .	65
5.6. - Tools . . . . .	65
<b>CHAPTER 6. - SPARE PARTS</b> . . . . .	<b>66</b>
6.1. - Seal kit . . . . .	66
6.2. - Maintenance kit . . . . .	66
<b>CHAPTER 7. - TROUBLESHOOTING</b> . . . . .	<b>67</b>
<b>CHAPTER 8. - ACCESSORIES</b> . . . . .	<b>70</b>
8.1. - Oil mist eliminator . . . . .	70
8.2. - Liquid nitrogen trap . . . . .	76
Diagram 1 Dimensions	
Diagram 2 Removal lip seals	
Diagram 3 Electric motors	
Diagram 4 Table of pumps and accessories recommended for different applications	
Diagram 5 Connecting accessories and vacuum fittings General drawing and nomenclature	

N O T E S

**APPLICATIONS AND LIMITATIONS :**

Alcatel vane pumps are designed to ensure complete safety for the worker and the workplace when used properly. It is the user's responsibility to follow the warnings, precautions, and maintenance requirements set forth in this manual.

**IMPORTANT NOTE :** ALCATEL hermetic 2033/2063 H are designed to pump or transfer expensive or dangerous fluids (helium 3, radio-active gases...)

**EQUIPMENT INSPECTION ON DELIVERY :**

The equipment has been thoroughly tested, checked and carefully packed before leaving the plant.

Shipper assumes responsibility for delivery. No claims relating to condition of materials shipped will be accepted unless submitted within eight days of receipt of goods.

**No returned materials will be accepted without prior authorization of ALCATEL.**

Before unpacking equipment, please look at parag. 3.1. If the equipment must be stored, see parag. 3.2. We reserve the right to cancel the warranty :

- If the equipment is disassembled without authorization of ALCATEL.
- If spare parts not made by us are used.
- If corrosive gases are pumped.

CHAPTER 1 - INTRODUCTION

1.1 - DESCRIPTION OF PRODUCT -

ALCATEL oil-sealed vane pumps are used in every application of vacuum technology (laboratories, etc...).

They can only be used to obtain a medium vacuum (up to  $10^{-3}$  mbar) or in pumping assemblies, for example to back a diffusion pump or turbomolecular pump.

Pumps in the 33/63  $m^3.h^{-1}$  series have the following features in common :

- Direct transmission makes them highly compact and an eye hook makes them portable.
- They are equipped with an antinoise system.
- An anti-suckback system ensures that the pump will retain its tightness when stopped inadvertently or accidentally.
- The inlet and exhaust connections are according to Pneurop standards and enable numerous accessories to be connected (see parag. 3.43).
- A sight glass on the oil case shows the oil level.
- The principal parts are provided with pins to facilitate disassembly, reassembly, and replacement of defective parts without affecting the specifications in the manual.

"AR" series hermetic pumps are designed especially for pumping and transferring expensive or dangerous fluids such as :

- Hélium 3, used in cryogenics.
- The radioactive gases sometimes used in nuclear applications.

The special design of the H model ensures a tightness of  $10^{-7}$  atm.cc.s<sup>-1</sup> with respect to the surrounding environment.

An excellent seal for the chamber to be pumped down is obtained by the following methods :

- The oil casing is made of stainless steel sheet and all welds are checked with a helium leak detector. This solution, more reliable from the tightness standpoint, was chosen over castings because the latter may be porous to light gases such as hydrogen and helium.
- All o-rings are flush-mounted. The grooves are shaped such that the rings are compressed 30 %. This ensures optimum sealing reliability.
- The rotary seal (78 C) in the shaft opening works with two other seals (81 (A and B) (see figures 1A and 1B from parag. 4.3). The two additional seals form a sealed compartment immersed in oil. If one of these seals deteriorates, it will become apparent from the level in oil sight glass (93). The operator can then intervene before the second seal is destroyed.

The operating conditions, which are a function of the pump's exhaust pressure, are given in parag. 4.4.

**1.2 - ELECTRICAL CHARACTERISTICS -**

The pumps can be supplied with different types of motors (voltage, frequency, type of motor protection...). Depending of the destination, the motors can perform differently, in accordance with the user's country.

The tables on diagram 03 "Electrical motors", indicate the characteristics of different standard motors. Upon request, other types of motors can be delivered (special voltage, explosion proof...).

**1.3 - TECHNICAL SPECIFICATIONS -**

P U M P	UNIT	2033 H		2063 H	
Frequency	Hz	50	60	50	60
Nominal rotational speed	tr/mn	1500	1800	1500	1800
Number of stages		2		2	
Nominal pumping speed (Pneurop)	m <sup>3</sup> /h	35	42	65	78
	CFM		27		50
Ultimate pressure *	mbar	< 10 <sup>-4</sup>		< 10 <sup>-4</sup>	
Exhaust pressure (max.)	bar	2		2	
Internal gas volume	cm <sup>3</sup>	3200		3540	
Cooling water flowrate	l/mn	1		2	
Water pressure	bar	3		3	
Oil capacity (main casing)	l	4,6		7,5	
Oil capacity (intermediate chamber)	l	0,12		0,27	
Weight (with motor)	kg	74		107	
Inlet and exhaust Pneurop flange		NW 40		NW 40	

\* Measured by Pneurop method.

The above characteristics assume that the pump is filled with Alcatel 100 oil and is at 1.5 bar absolute exhaust pressure. These characteristics can vary when other oils or different exhaust pressures are used.

**1.4 - SIZE -**

See diagram 01 at the end of this book.

## CHAPTER 2 - OPERATING PRINCIPLE

### 2.1 - SINGLE-STAGE MECHANICAL PUMP -

The functional part of a mechanical pump is composed of :

- A hollow cylindrical stator with inlet and exhaust valves.
- A rotor mounted eccentrically inside the stator for pumping.
- Two vanes sliding in the rotor, forced against the stator by centrifugal force and springs.

The pumping cycle is as follows :

- Intake : as the vane passes in front of the inlet orifice, an increasing space is formed into which the gas from the chamber to be evacuated expands. When the second vane passes, the space is closed.
- Transfer : the gas trapped in the space between the two vanes is transferred to the exhaust orifice as the rotor rotates.
- Compression : the space communicates with the exhaust, which is fitted with a valve : the gas is compressed until open the valve.
- Exhaust : the gas is expelled into the oil casing when the pressure is sufficient enough to open the discharge valve.

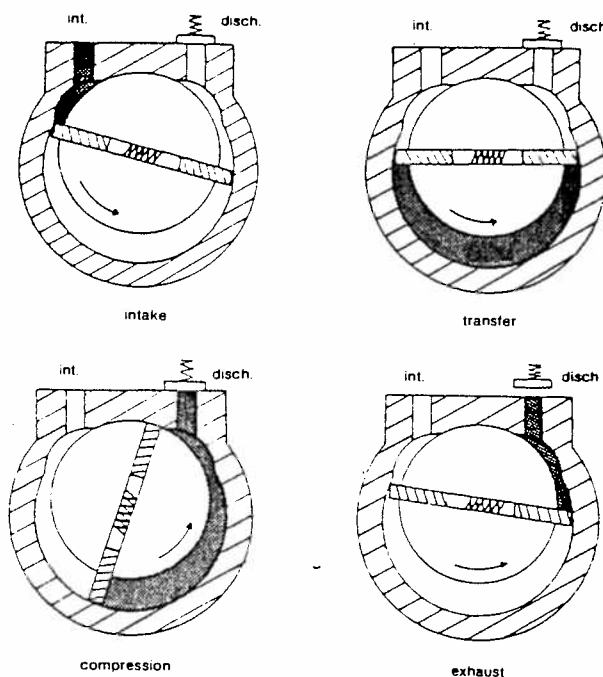

Fig. 2.1



## 2.2 - TWO-STAGES PUMP -

To improve the backing pressure and displacement at low pressure, two stages are connected in series. The second is similar to the first both structurally and operationally. The gases pulled in by the first (low-pressure) stage are transferred to the second (high-pressure) stage, then discharged through the HF valve.

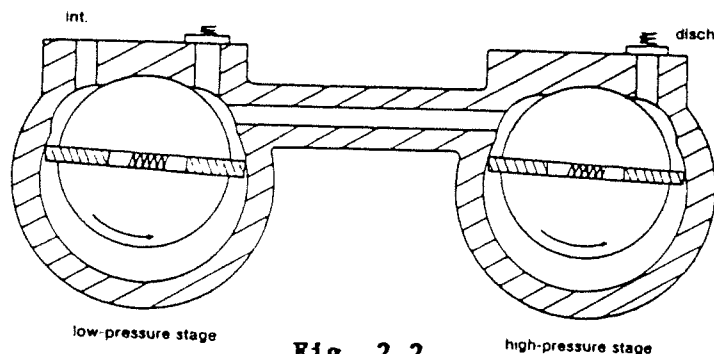

Fig- 2.2

## 2.3 - OIL -

Oil has several important functions in the pump :

- It lubricates mechanical components (bearings, shaft seals, rotor, vanes, etc...).
- It makes moving parts relatively tight by limiting internal leakage.
- It carries away the heat produced by the compressed gases.

ALCATEL has selected various types of oil for its pumps ; they are listed in parag. 3.32.

## 2.4 - LUBRICATION (see figure 2.6) -

In operation, the oil pump draws cold oil from the bottom of the oil case (the oil is cooled by the fan). The oil is forced into the diaphragm-spring system (n° 46 and 47, from fig. 2.6). The discharge pressure of the oil pump lifts the diaphragm off its seat, allowing oil to reach the moving parts via the oil injection line to escape when the pump starts.

## 2.5 - ANTISUCKBACK -

When the pump is stopped or the current is turned off, an antisuckback device isolates the functional part of the pump against air or oil returning to the chamber being evacuated. The seal is ensured :

- By flush-mounted O-rings between the surfaces of the functional elements (stators, flanges, frame, etc...);
- By spring-loaded check valves in the discharge ports ;
- By a diaphragm and spring system which automatically seals the oil injection duct (A) in the pump. The operating principle is as follows (see diagram in parag. 2.5) :

When the pump stops, the discharge pressure of the oil pump (B) drops. Diaphragm (47), under pressure from the spring, is forced against its seat (46), thus closing off the injection line (A).

2.6 - NOISE LIMITER :

When the pump begins to operate the oil (C) pulled in by the oil pump (B) is drawn in through oil inlet tube (52) and is agitated by a venturi tube (D).

At the end of the gas intake tube (53) mounted parallel to the oil flow, a negative pressure is created. Because of the negative pressure created at the end of the venturi (53) gases are entrained into the moving layers of oil dampening pump noise. The added gases will affect the ultimate pressure, therefore, a compromise between sound level and ultimate pressure has to be reached as follows :

- Tightening down gas intake tube (53) decreases the oil flowrate at the intake of the oil pump (B) and increases the amount of gas mixture in the oil. The sound level decreases but the ultimate pressure increases.
- Unscrewing tube (53) increase the oil flowrate at the intake of the oil pump (B) and decreases the amount of gas mixture with the oil. The sound level increases but the ultimate pressure decreases. This adjustment can be performed via the oil fill port while the pump is in operation.

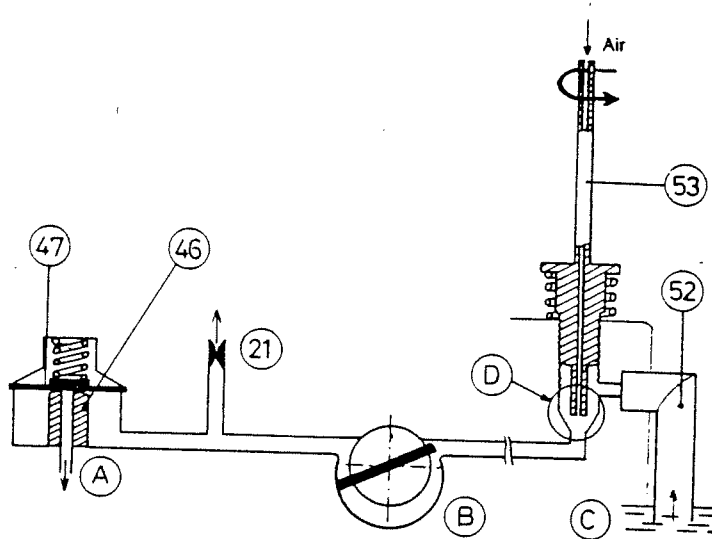

Fig. 2.6

## 2.7 - ROLL OF THE SEALED COMPARTMENT -

In a standard pump, when the shaft seal is deteriorated, there is an oil leakage to the outside of the pump (or inverse), and forwards, gas leakage. The operator finds out its, when gas is flied.

Roll of sealed compartment of hermetics pumps is to avoid gas leakage and prevents the operator from seals deterioration (81 A or 81 B). When the oil level rise into intermediate compartment, this indicates an oil and gas leakage from pumped chamber to outside. An oil level falling indicates an opposite leakage. The operator is advised and can intervene before leakage becomes important.

Parag. 4.3 relates instructions to use sealed compartment.

N. B. : for more safeties, chamber can be :

- surpressed (+ 0,2 bar).
- Supplied with gas purge to dilute pumped gas.
- Charged with neutral gas.

### CHAPTER 3 - MOUNTING AND INSTALLATION

IMPORTANT NOTE ! For any given application, pump performance will depend on :

- Mounting conditions and accessories.
- Type of oil used.
- Mechanical connections : lines, etc...

The reliability of an hermetic serie pump usually operated in a nuclear atmosphere, depends on how it is maintained. After installing a vacuum system, provide the accessories required for its maintenance (valves, purges, etc...).

For safety reasons, use accessories at the pump inlet and exhaust whose materials and tightness are compatible with the gases being pumped. We strongly advise reading sections chapter 3, 4 and 5 before installing the pump contact ALCATEL if there is any assistance required.

#### 3.1 - UNPACKING -

Unpack equipment carefully upon receipt. Do not discard packing material until pump has been checked for damage in shipment. If damage is found, proceed as required with shipper and advise ALCATEL if necessary. Pump contains no oil when delivered : oil is shipped in separate containers.

#### 3.2 - STORAGE -

If the pump is to be stored, reliability without special storage precautions is guaranteed for up to 3 months at an ambient temperature of 5 to 40 °C.

After 6 months, factors such as temperature, humidity and salt air can cause deterioration of certain components : o-rings will harden, shaft seals will bond to shafts, and oil will become contaminated. A pump may experience operating difficulties under these conditions. Before it is started, it will have to be disassembled (see parag. 5) and all the seals replaced (see parag. 5.4).

Note 1 : we recommend keeping the pump filled with oil if it will be stored for longer than three months. To do this, fill pump according to parag. 3.51, and run it for one hour at ultimate vacuum, so that all parts will be lubricated (see parag. 4.1). Then, stop the pump and store it after sealing inlet and exhaust ports tightly (quick-connect clamp, centering ring, plug ...).

Note 2 : seal kits should also be stored carefully. Keep them away from heat and light (sunlight and ultraviolet) to prevent any hardening of the elastomers (see parag. 6.1).

3.3 - CHOOSING THE OIL -

3.31 - WHY CORRECT OIL IS IMPORTANT :

Oil has numerous functions in the pump (see parag. 2.3). The correct oil is critical for a good vacuum. The choice depends on :

- Chemical aggression and corrosion of the pumped products.
- Used accessories.
- Maintenance intervals that you want be compelled.
- Total operating cost.

Different oils produce different partial pressures in the same pump. The partial pressure depends on the saturated vapor pressure of the oil, its viscosity and its ability to dissolve gases. Synthetic oils in particular produce a significant rise in the ultimate pressure of two-stages pumps.

3.32 - RECOMMENDED OILS :

For the hermetic pumps series, ALCATEL recommends oils listed in the table below. Oils with similar characteristics can be used, however.

OILS	A P P L I C A T I O N S	* INFLUENCE ON ULTIMATE VACUUM OF A TWO-STAGE PUMP	LIMITATION ON USE
ALCATEL 100	General purpose paraffin-based mineral oil : . Good base pressure . Low backstreaming	-5 5.10 mbar	Flammable
ALCATEL 102	Anti-emulsion mineral oil : . Drying . Pumping water vapor . Freeze-drying	-4 3.10 mbar	Flammable
ALCATEL 111	Hydrocarbon-based synthetic oil with good heat resistance . Pumping at high pressures	-3 2.10 mbar	Flammable
ALCATEL 200	Mineral oil vacuum distilled . Pumping corrosive products . Reduced backstreaming	-5 5.10 mbar	Flammable

\* Partial pressure measured by Pneurop method with a 2012 AH ALCATEL pump.

However, ALCATEL 100 oil can be replaced by the following fluids :

- ELF MOVIXA PV 100.
- ESSO TERESSO 100.
- ELF BARELF F 100.
- BP CS 100.
- INLAND 15.
- INLAND 19.
- SHELL VITREA 100.
- TOTAL CORTIS 100.
- INVOIL 20 \*

In this case, the characteristics can be different from those listed on paragraph 1.3 and in the table above.

\* Registered trademark INLAND

### 3.4 - SET UP -

**WARNING** ! The position of leap seals from intermediate compartment depends of the application. In its standard state, pump is delivered to work with a discharge pressure above atmospheric pressure (see fig. 1 A in parag. 4.41). When pump works with a discharge pressure below atmospheric pressure, position of leap seal (81 B) must be changed. To do this, proceed as follows :

- Disassemble the pump (see parag. 5).
- Reassemble the pump mounting seal (81 B) in reverse position (see fig. 1 B from parag. 4.42).

#### 3.41 - FILLING MAIN CHAMBER WITH OIL :

Unscrew filling plug (65) on oil casing. Fill with oil up to the middle of sight glass (64) on casing. This operation must be performed while the pump is stopped.

#### 3.42 - FILLING INTERMEDIATE CHAMBER WITH OIL :

Unscrew plug (66) on frame. Fill with oil up to the middle of sight glass (93 on frame). Tighten plug (66).

#### 3.43 - MECHANICAL CONNECTIONS :

- a) Mounting on a frame : the pump can be mounted on a frame by using the 4 mounting holes in base (2) and 4 special shock mounts (see 3.44).

Notes : these mounts reduce the pump vibrations but will not hold the pump securely when the pumping assembly is moved. Clamp pump to frame before moving.

- b) Ventilation : the pump and motor are equipped with a ventilation system. When the pump is installed, the pump should be placed in a ventilated location. **Check ventilation holes on the pump and motor periodically for obstructions.**

ALCATEL pumps are designed to operate at an ambient temperature of 10 to 40 °C. If the temperature is likely to rise above 40 °C, an auxiliary cooling device can be used (see parag. 3.44).

- c) Inlet and exhaust ports : the pump inlet and exhaust ports are equipped with ISO NW 40 nipples for Pneurop quick connectors to accept various stainless steel, etc..., tubing accessories (see diagram 5).

d) Cooler connections :

Male end connectors (29) 1/8" located on the rear casing must be connected to water line. Flows and pressures indicated parag. 1.3 must be respected. Water inlet temperature must be between + 15 °C and 25 °C.

3.44 - ACCESSORY TABLE :

DESIGNATION	PART NUMB.	LOCATION	FUNCTION
Oil mist eliminator	068744	exhaust	Separates oil droplets and contaminant particles in exhausted gases from the mechanical vacuum pumps.
Molecular sieve filter	053380	inlet	Prevents oil backstreaming (when used to back a diffusion pump or TMP).
Liquid nitrogen trap	786537	inlet	- Protects pump against condensable vapors. - Prevents oil from backstreaming into pumped chamber
Auxiliary cooling device	054257	between frame and motor (only 2033 H)	When operating at ambient temperatures above 40 °C, a water cooling ring can be fitted.
Shock mount	082692 (APEX LXA 88 Mod. D)	between base and machine frame	Allows pump to be mounted on a frame.

In general, use accessories whose tightness and materials are compatible with the pumped gases at both the inlet and exhaust, and overpressure at the discharged.

See table "selecting pumps and accessories for specific applications" at the back of this manual (diagram 4).

3.45 - ELECTRICAL CONNECTION :

Generally speaking, the motor should be fused for 120 % of its rated current. For series motors, see table "protection of electric motors (see diagram 3).

a) Three-phase version : hook up motor according to line voltage. The connections are shown on the schematic located inside the terminal box or on the lid. The pumps are delivered with their motors connected to maximum voltage. Switch on current briefly to check motor rotation direction. The end of the shaft must rotate in the direction of the arrow on the motor mounting plate.

## CHAPTER 4 - OPERATION AND MAINTENANCE

### 4.1 - START UP

#### 4.11 - TEMPERATURES

- Starting : be sure oil bath temperature is above 10°C before starting motor.
- The ambient temperature where the pump will be used must be between 10 and 40°C.
- Under these conditions, the pump temperature (measured at the front flange) must be between 60 and 80°C (depending on operating conditions).

#### 4.12 - STARTING AFTER DISASSEMBLY AND REASSEMBLY

- After maintenance or a change in oil type, the functional parts of the pump will be under-lubricated. Before running pump under hard conditions (continuous or high-pressure operation), proceed as follows :
  - Remove exhaust port (67). Use a screwdriver to unscrew air inlet tube (53) completely to facilitate the initial startup of pump oil circuit.
  - Check motor rotation direction
  - Perform operations in parag. 4.13
  - With pump hot, adjust noise level (see parag. 4.2).

#### 4.13 - NORMAL STARTUP

The pump has been stopped but not disassembled. This is also the case for the initial startup.

- a) Make sure oil bath temperature is above 10°C
- b) Start pump.
- c) Allow pump to run for one hour at ultimate vacuum. During this operation, make sure oil circuit is operating. (For this reason, do not replace exhaust port 67).

When pump starts, the oil pump expels the air out of the oil inlet tube (52) and exhausts it through the exhaust jet (21) (see figure 2.6) and hence out of the vacuum pump. As a result, air bubbles appear in the oil around the jet (21).

When the oil circuit starts, loud popping sounds will be heard (first irregularly, then regularly) which will silence as the oil heats up. As soon as port 67 has been replaced these noises will no longer be heard.



After the pump has started, a layer of bubbles from the HP stator gradually spreads across the surface of the oil bath. This emulsion disappears when the oil reaches operating temperature.

Under normal temperature conditions, the oil circuit should start one minute after startup (this time can vary with the type of oil and its degree of contamination).

It is normal for the oil level to rise (as can be seen through the oil sight glass) when the pump is hot due to expansion of the oil and starting of the oil circuit.

In the event of malfunction, see parag. 7. " Troubleshooting ".

#### 4.14 - SPECIAL CASES

When a pump must start cold (ambient temperature about 10°C) or when it has to start cold after pumping contaminating products or condensables, proceed as follows :

Unscrew air inlet tube (53) to the maximum extent to help oil circuit to start. Readjust antinoise system once pump is hot (see parag. 4.2).

On the other hand, when you have pumped on dangerous products (corrosive, toxic...), you must reheat the pump to reach the pump starting temperature.

#### 4.2 - USING NOISE LIMITER

The principle of this system is described in parag. 2.6. It is adjusted at the factory when the pump is checked and need only be readjusted after :

- Pump disassembly-reassembly operations ;
- Changing the oil type (not all oils are miscible in the same proportions with pumped gases).

To adjust antinoise system :

- Set pump to normal operating condition (temperature, ambient sound level, etc.) ;
- Connect a liquid nitrogen trap and a Penning gauge to pump inlet ;
- Remove fill exhaust port (67) and unscrew gas inlet tube with a screwdriver all the way out ;
- Run pump for about one hour at ultimate vacuum ;
- Screw in tube (53) half a turn at a time, monitoring partial pressure and sound level (wait 3 to 4 minutes after each half turn). Then set to desired point (to evaluate sound level, replace exhaust port (67)).

### 4.3 - HIGH-PRESSURE PUMPING

" H " series hermetic pumps are designed to be used in lower pressure applications (inlet ultimate pressure below 60 mbar).

#### Intermittent Pumping

If the pump operates only a short time at high pressure, top off with lubricating oil following the return to low pressure. Use an oil mist eliminator to prevent splashing and misting losses (see parag. 8.1)

#### Continuous Pumping

When pump operates continuously at high pressure, oil consumption may rise to the point where the level in the oil case drops. The pump may then seize due to a lack of oil. The high throughput of gas through the eliminator has prevented oil from flowing back into the pump.

Under these conditions the pump and oil mist eliminator must be modified as shown in the diagram annexed. A device of this type draws the oil from the eliminator through the pump for lubrication.

The components of a system of this kind will depend on the ultimate vacuum desired, the volume of gas pumped, and the oil used. Other arrangements are possible ; contact ALCATEL for assistance.

#### **HIGH PRESSURE PUMPING : Example of oil recovery device**

( WARNING : The pump is not airtight )

Fig. 4.3

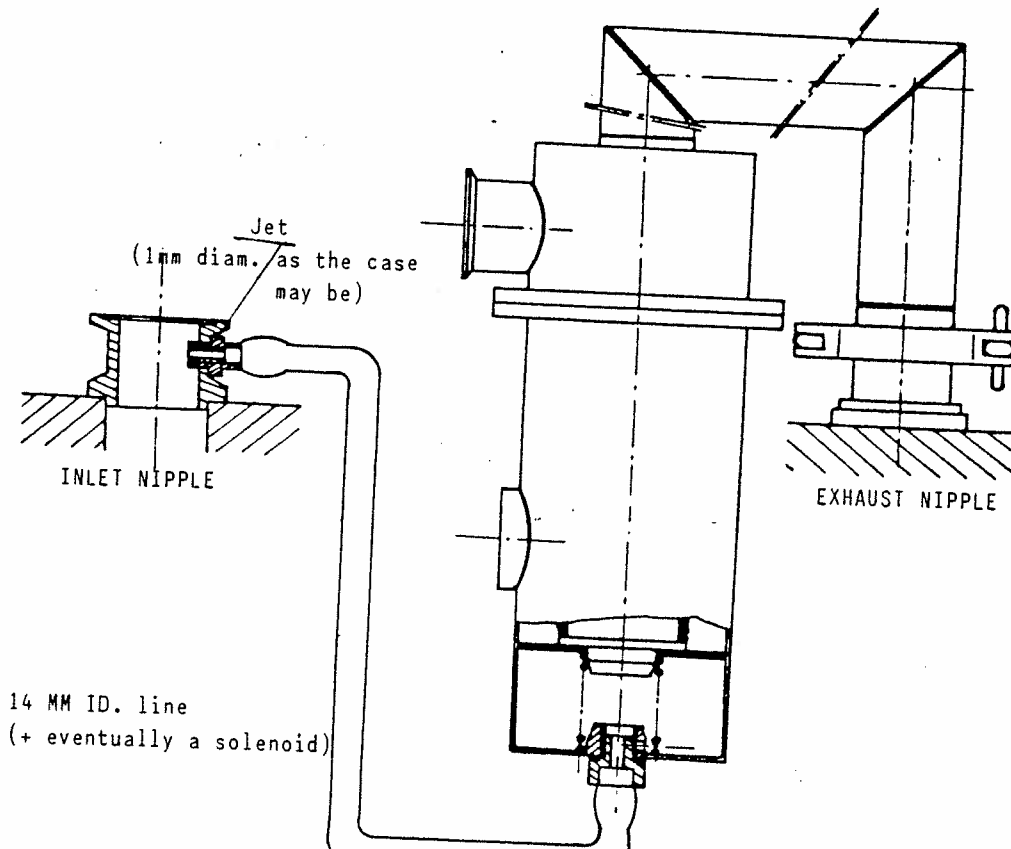

#### 4.4 - USING INTERMEDIATE CHAMBER

The operating conditions are a function of the pump's exhaust pressure. Before use the pump, check that the shaft seal (81) B is correctly installed (see parag. 3.4 WARNING).

#### 4.41 - DISCHARGE PRESSURE ABOVE ATMOSPHERIC PRESSURE (1 to 2 bars absolute)

PUMPS ARE DELIVERED IN THIS CONFIGURATION

FIGURE 1A

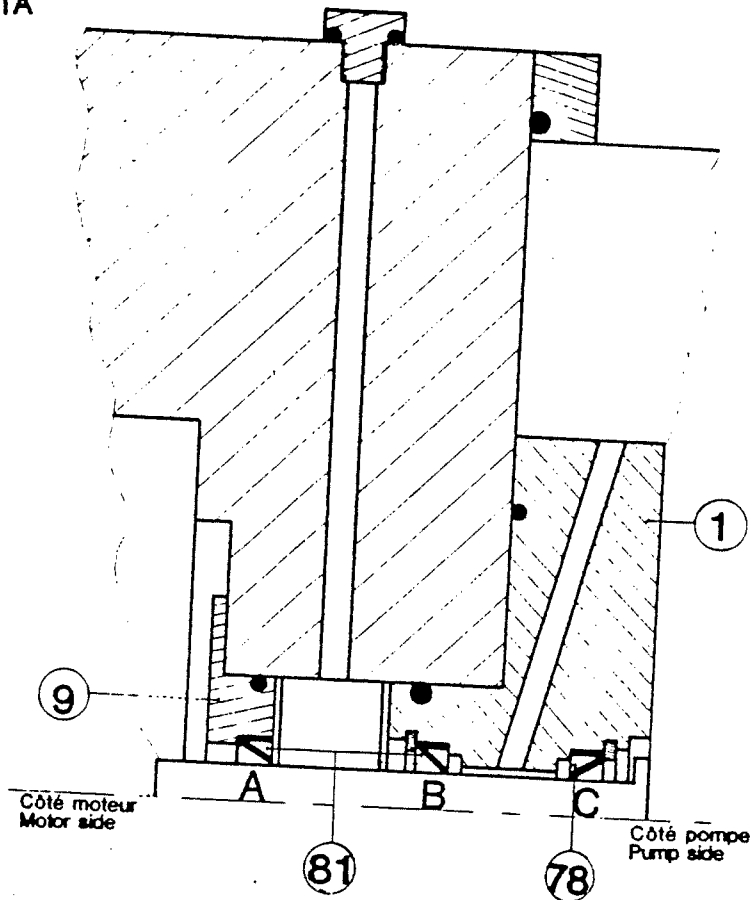

Seals (78) C and (81) B are mounted in the reverse direction.

The bearing between seals (78) C and (81) B is at a pressure above atmospheric pressure. The chamber between (81) A and (81) B is at atmospheric pressure, seals (78) C and (81) B are tightened on the shaft.

Oil and pumped gas leakage from bearing to intermediate chamber is minimal.

When shaft seal (81) B is deteriorated, gas flies into intermediate chamber. To avoid outside gas leakage, you can dilute oil with a neutral gas flow : this permits oil degassing and chamber flushing to reduce gas accumulation.

An oil level fall from intermediate chamber indicates the (81) A seal destruction.

An oil level rise from intermediate chamber and an oil casing level fall indicates the (81) B seal destruction.

4.42 - DISCHARGE PRESSURE BELOW ATMOSPHERIC PRESSURE (from 0.5 to 1 bar absolute)

FIGURE 1B

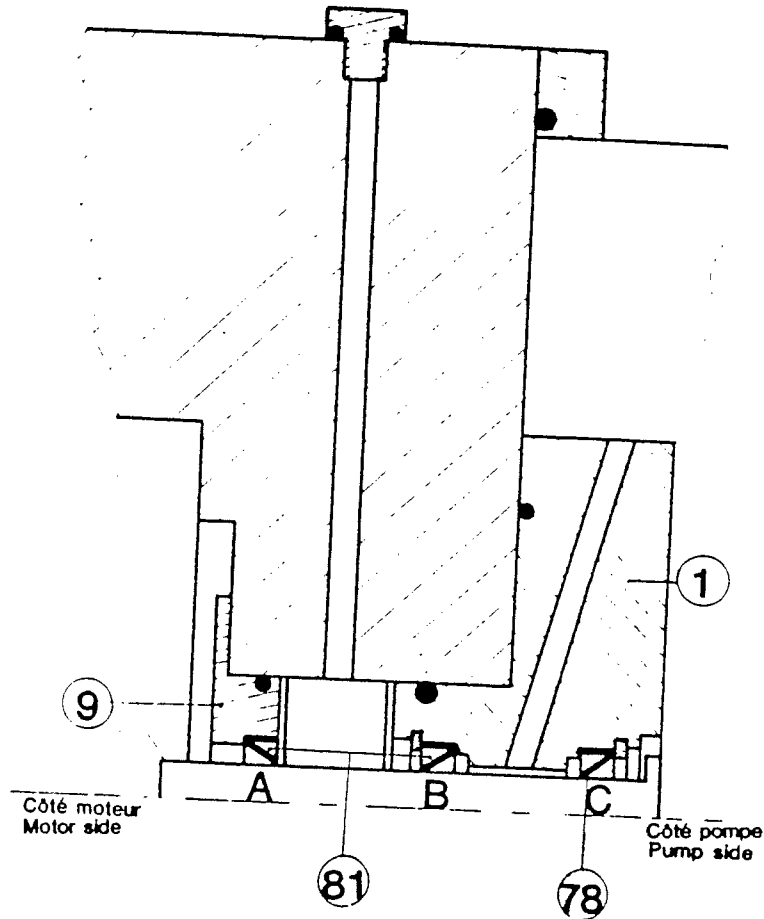

The bearing between seals (78) C and (81) B is at casing pressure - chamber between seals (81) B and (81) A is at atmospheric pressure, seal (81) B is tightened on the shaft ; oil leakage from the intermediate chamber to the inside of the pump is minimized. Pumped gas can never flies outside.

When seal (81) B is deteriorated, gas from intermediate chamber flies into casing, into pumped gas. To avoid this mixture, you can surpressed (0.2 bars) intermediate chamber, with a gas similar to pumped gas (to preserve the purity).

Opposite view, if seal (81) A, is defect, you can have leakage to outside. In this case, the pumped gas must be pure, no dangerous.

An oil level fall from intermediate chamber indicates the (81) A seal destruction.

An oil level fall from intermediate chamber and an oil level rise from casing indicates the (81) B seal destruction.

4.43 - NOTES

Generally, avoid to depress intermediate chamber to not disturb (81) A seal working. Supress rather this chamber. In routine utilization, this surpressure result from oil expansion due to warmth into intermediate chamber.

#### 4.5 - CHANGING FROM ONE TYPE OF OIL TO ANOTHER

ALCATEL pumps are tested with ALCATEL 100 oil and a certain quantity of test oil remains in the pumping system.

To use another type of oil, proceed as follows :

##### a) When oils are compatible

This is the case when one mineral oil is replaced by another (e.g. ALCATEL 100 by ALCATEL 102).

Simply flush pump (see parag. 4.7) using new oil, then fill (see parag. 3.41).

##### b) When oils are incompatible (synthetic oils or similar oils)

This is the case when a mineral oil is replaced by a synthetic oil (for example ALCATEL 100 by ALCATEL 111).

To change oil, proceed as follows :

- Disassemble pump completely and clean (see parag. 5).
- Replace all seals (parag. 5.4. Change the three shaft seals (78) by viton shaft seals P/N 079101.
- Reassemble but remove intermediate plate jet (22).
- Fill with new oil (see parag. 3.41).

#### 4.6 - OIL LEVEL - DRAINING

##### a) Oil level

To use pump under optimal conditions, check oil level in oil sight glass periodically. **Do this when pump is not operating.**

- . Oil consumption may vary with conditions. Use of an oil mist eliminator can substantially reduce oil consumption by allowing oil recuperation.
- . Periodic inspection enables the oil color to be compared with a sample of fresh oil. It indicates the degree of contamination or degradation.

**If the oil is brown, blackish, or smells " burnt " it has deteriorated. In this case, drain pump and rinse if necessary.**

##### b) Draining

The pump must be drained when hot and after the oil case has been vented to atmospheric pressure . First, isolate or disconnect the pump from the system. Then :

- Tilt pump (see below)

#### Main chamber draining

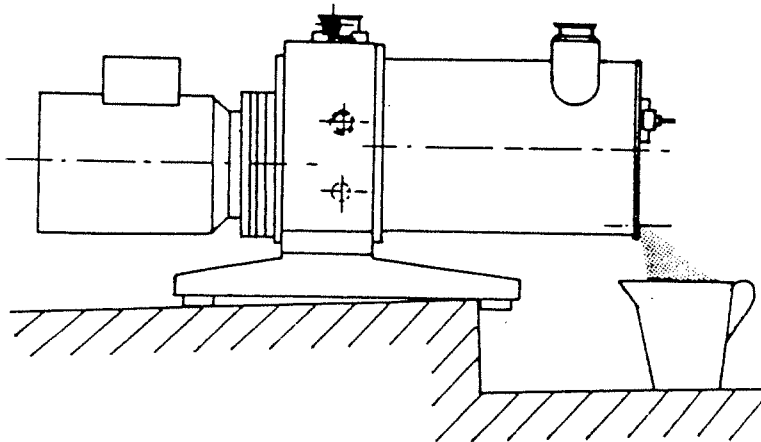

Fig. 4.62

- Unscrew drain plug (66) on oil casing. When all the oil has drained, replace plug (66) temporarily and run pump for about 10 seconds leaving inlet port open. This removes the oil from the pumping module.
- Drain this oil by removing plug (66).
- Replace plug, then fill with fresh oil up to the middle of oil sight glass (64).

#### Intermediate chamber draining

- Unscrew fill and drain plugs (66) on frame.
- When all the used oil has run out, replace drain plug (66) and fill with oil up to the middle of the sight glass (93).
- Replace fill plug (66).

### 4.7 - FLUSHING

Draining can be followed by rinsing if the oil is particularly dirty. This operation requires a volume of oil equal to the capacity of the pump. After draining oil case (see parag. 4.6) replace plug (66). Remove inlet filter (39), clean, and replace. Run pump at atmospheric pressure, allowing fresh oil to flow slowly into inlet (24). Stop pump and drain rinse oil via drain plug (66). Replace plug and top off with fresh oil according to parag. 3.41.

CHAPTER 5 - DISASSEMBLY, CLEANING AND REASSEMBLY

**IMPORTANT NOTE !** Before any maintenance is performed, remember to provide protection against toxicity, corrosion, and radioactivity of pumped gases. Depending on the individual situation, we recommend the following :

- flush system with dry nitrogen before maintenance is performed ;
- wear gloves, goggles, and gas mask if necessary ;
- make sure room is properly ventilated and disassemble pump under an exhaust hood ;
- collect residues in appropriate containers and if necessary have them destroyed by a competent organization.

Routine maintenance of ALCATEL hermetic 2033 H and 2063 H pumps requires only periodic oil changes.

In the event of heavy contamination or an operating breakdown, the pump must be disassembled (see parag. 7.)

Replace all seals whenever the pump is disassembled (see parag. 6.1).

The only tools needed are a few wrenches, found in any maintenance shop (see parag. 5.6).

Before disassembly, drain oil (see parag. 4.6):

The first step is to remove the motor ; the second step is to disassemble the moving parts.

**5.1 - REMOVING MOTOR** (see general drawing)

- Unscrew four nuts (K)
- Remove motor assembly and motor mounting plate (103). The coupling separates into two halves, one on the motor side, the other on the pump side.

**5.2 - DISASSEMBLING MOVING PARTS**

**5.21 - MOTOR**

- Prevent fan (61) from rotating by wedging a wooden chock against the side of the frame and two blades of the fan.
- Remove elastomer coupling (62)
- Unscrew self-locking screw (J) (not reusable) and remove washer (V).
- Using two 8 mm extraction screws, remove fan (61) and chock.
- Remove screws (E) and, using two 6 mm extraction screws, remove cover (9) with seal (81) A.

**5.22 - REMOVING OIL CASING**

- Unscrew four nuts (K) and remove the oil casing (3) and its gasket (63).

**5.23 - DISASSEMBLING PUMPS (2033 H and 2063 H)**

**a) Removing valve cover**

- Remove valve covers (27) and (30) by loosening screws (X, S).
- Remove valve springs (28) and valves (29).

**b) Removing Oil Pump (42)**

- Remove screws (B) and body (42)
- Remove vane (44).  
Remove screws (G) and cylinder (51), spring (50), and diaphragm (47).
- Remove seat (46) and O-ring (49).
- Remove screw (AA) and stop (15).
- Remove oil inlet tube (52).
- Unscrew air inlet tube (53) and remove spring (54). (If necessary, note setting of air inlet tube (53) : number of turns until tube stops moving turning clockwise).

**c) Removing Rear Plate (7)**

- Unscrew four nuts (K).
- Insert two screwdrivers into the two notches and twist to remove plate off pins. Pull plate straight out, holding HP rotor (19) in place.  
Remove O-ring (14).

**d) Removing HP Rotor (19)**

- Remove rotor (19) by sliding it out of stator (6).
- Remove vanes (20) and their springs (18).

**e) Removing HP Stator (6)**

- Insert two screwdrivers into the two notches and proceed as in parag. c).
- Remove O-ring (14).



**f) Removing Central Plate (5)**

- Insert two screwdrivers into the two notches and proceed as in parag. c).
- Remove O-ring (14).
- Oil jet (22) lubricates the first stage. Do not remove it for cleaning. When reassembling, spray with compressed air to remove any obstructions.
- Remove tube (12) and O-ring (13).

**g) Removing LP Rotor (16).**

- Remove rotor (16) by sliding it out of stator (4).
- Remove vanes (17) and their springs (18).

**h) Removing LP Stator (4).**

- Remove nuts (K).
- Insert two screwdrivers into the two notches and proceed as in parag. c).
- Remove O-ring (14).
- Remove tube (12) and O-ring (13).

**i) Removing Front Plate (1)**

- Unscrew for nuts (K).
- Insert two screwdrivers into the two notches and proceed as in parag. c).
- Remove O-ring (14) and shaft seals (78) and (81) B.

**j) Disassembling inlet nipple (24) (on frame)**

- Remove four screws (M) and remove clamps (41).
- Remove nipple (24) and its O-ring (40).

**k) Disassembling exhaust nipple (67) (on oil casing)**

- To remove exhaust nipple (67), the nipple must be connected to a line with an NW 40 centering ring with O-ring and quick connect clamp. Use the latter to unscrew nipple (67).
- Remove O-ring (74).
- Remove pin (71) and remove filter (72), sleeve (73). shaft (68)

### 5.3 - CLEANING METAL PARTS

Cleaning metal parts requires the use of solvents. Be sure to take all normal precautions and obey manufacturers' instructions.

- **After using mineral oils**, clean metal parts with solvents such as 1,1,1-trichloroethane or 1,2-dichloroethane, hot or cold.
- **Cold-cleaning** : clean parts by immersion and with brushes (do not use rags).
- **Hot-cleaning** : use appropriate equipment and take necessary precautions (baskets ; evacuation of fumes).

### 5.4 - REPLACING SEALS AND OTHER ELASTOMER PARTS

**REPLACE ALL SEALS AFTER EACH DISASSEMBLY.**

If you must reuse an elastomer part (seal, valve, etc.), never clean this part with a solvent without finding out the effects on the technical characteristics of the elastomer. **If this is not done, we cannot guarantee that the pump will operate properly.**

#### 5.41 - O-RINGS

Shore hardness is between 60 and 70. O-rings must not be scratched or cracked, and must be circular in cross section. Never use cord with an oval cross section.

#### 5.42 - SHAFT SEALS

##### **Disassembly**

- Place part (frame or plate) flat on a work bench.
- Place a washer (22 x 40 x 3 mm) on seal as a support.
- Insert one end of a screwdriver under shaft seal.

#### **IMPORTANT**

**Be sure not to damage seal seat during removal**

- Use screwdriver as a lever : press against washer, pry loose, and discard (see diagram 2).

### Fitting a New Seal

- Clean seal seat and smooth any rough edges.
- Lubricate bore and entire seal.
- **Position seal in the proper direction** (see general drawing and parag. 4.41 or 4.42).
- Mount seal on pre-oiled mounting mandrel.
- Locate seal opposite seat and install :
  - . With a press and the proper mandrel (case 2, diagram 2),
  - . With a drill press, or
  - . by striking mandrel (case 1) with a mallet. In this case, keep mandrel perpendicular to housing.

To remount plates use protective sleeve (see diagram 2) (oil it well before mounting plate) or wrap end of shaft with adhesive tape.

#### IMPORTANT

Replace viton shaft seals (81) A and B correctly :

- red seal (81) A is located on cover (9)
- red seal (81) B is located on front plate (1), motor side

### 5.5 - REASSEMBLY

#### 5.51 - GENERAL INSTRUCTIONS

Oil used for lubricate pump parts must be the same as oil used for pump operation.

Before reassembly :

- a) **All parts must be dry** so that no solvent remains, particularly in blind holes.
- b) **Do not put too much oil in the bottoms of the holes for the plate / stator alignment pins.**
- c) **Coat all pump parts and lips of shaft seals with clean oil.** Make sure seals are correctly installed (see general drawings).

**Fill lubrication holes of bearings and seal seats with oil.**

- d) Tighten nuts (K) without forcing (maximum torque 1.5 mdaN) ~ 11 P. 16

1 mdaN = 10.197 N

### 5.52 - ASSEMBLING MOVING PARTS

**Note :** The bushings in the frame and plates can be replaced, but special machining is required whenever a bushing is changed. Consult ALCATEL for assistance.

- Reassemble moving parts in reserve order of disassembly.
- Before replacing valves, pour a little oil into the stators through the valve holes.
- Before reassembling oil pump, assemble fan using a new self-locking screw (J) to tighten it.

### 5.53 - ASSEMBLING OIL PUMP

Before assemble it, put fan (61).

Mount all necessary parts on oil pump body (42) proceeding in reserve order from parag. 5.23 b.

- Place slot of oil pump rotor in **horizontal position** (parallel to pump base - see diagram).

Fan can be used to turn rotor but **NEVER INSERT A SCREWDRIVER IN THE ROTOR SLOT AS THIS MAY CAUSE DAMAGE.**

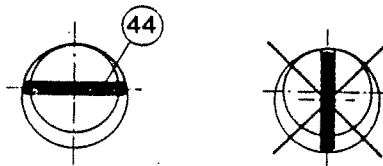

**Fig. 5.53 a**

- Place vane (44) in its slot.
- With pump horizontal, let pump body (42) drop by gravity on to rotor (as indicated in figure below).
- With pump vertical, turn pump body (42) clockwise around alignment pin (79) to bring it into contact with the rotor without forcing. Never rest pump body on rotor ; this will eliminate bearing play.
- Fit two screws B1 and B2 : B1 must be tightened first and B2 second (maximum torque : 1.1 mda N).

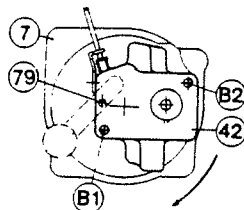

**Fig. 5.53 b**

**Moving parts : rear view.**

**Note :** When replacing air inlet tube (53), proceed as follows : Screw tube (53) all the way in then unscrew the number of turns given in parag. 5.23 b usually 3 or 4)

### 5.54 - MOTOR COUPLING

To make sure motor coupling (104) does not touch fan (61), adjust distance from motor plate (dimension A on the foldout drawing), as follows :

2033 H pumps	dimension A = $16.6 \pm 0.5$ mm
2063 H pumps	dimension A = $23.3 \pm 0.5$ mm

To perform this adjustment, use adjusting tool in tool kit (part n° 054284 ; see parag. 5.6).

### 5.6 - TOOLS

The tools required for disassembling and reassembling the motor pump assembly are listed below :

- No. 3 and No. 9 screwdrivers
- Open-end wrenches : 13-17 mm
- Allen wrenches : 4, 5, 6, 8 mm
- Slip-joint pliers
- 6 mm and 8 mm extraction screws.

#### Special ALCATEL Tools, N° 054284

To mount shaft seals and adjust motor plate, ALCATEL provides special tools in tool kit (see diagram 2).

DESCRIPTION	P/N
mounting mandrel	065089
protective sleeve	065088
washer	073331
coupling adjustment tool	065087
kit no.	054284

CHAPTER 6 - SPARE PARTS

For fastest service, specify the following when ordering :

- pump type
- serial number (on label)
- part number (see list at end of book).

Maintenance kits containing the most frequently used parts are always available at our sales outlets. Be sure to use these kits so you will have all the parts necessary.

6.1 - SEAL KIT

Pump	2033 H	2063 H
Kit N°	054282	054483

Contains all pumps seals for complete disassembly.

Seal kits should be stored carefully. Store them away from heat and light (sunlight and ultraviolet) to prevent any hardening of the elastomers (see AFNOR standard : " Conditions for Storing Vulcanized Elastomer-Based products " NF T 46022).

6.2 - MAINTENANCE KIT

In addition to seals this kit contains a set of spare parts for pump maintenance for up to two years of normal use.

Pump	2033 H	2063 H
Kit N°	054283	054484

CHAPTER 7 - TROUBLESHOOTING

PROBLEM	CAUSE	REMEDY	SECTION
A. PUMP DOES NOT ROTATE	1. Motor poorly supplied	Check wiring	parag. 3.45
	2. Pump seizes (stopping after pumping under difficult conditions - no drain or rinsing)	Disassemble, clean, and polish scratched metal parts (replace if necessary) then reassemble	" 5
	3. Coupling deteriorated	Disassemble motor and replace	" 5.1
	4. Temperature too low		" 4.11
	5. Oil contaminated	Change oil and rinse pump	" 4.6 + 4.7
	6. Oil gummed after prolonged storage or after stoppage after pumping contaminant substances	Disassemble, clean, reassemble	" 5
B. OIL PUMP DOES NOT START	1. No oil in case	Add oil	Parag. 3.41
	2. Inlet filter partially clogged	Clean filter	" 5.3
	3. Oil contaminated	See A.5	
	4. Oil cold		" 4.11
	5. Noise control system improperly adjusted	Adjust system	
	6. Lubrication holes clogged.	Disassemble and clean	" 5
	7. Oil pump vane worn	Replace	" 5

CHAPTER 7 - TROUBLESHOOTING (cont.)

C. VACUUM PUMP DOES NOT PRODUCE A VACUUM	<u>Check that oil pump has started.</u>	See parag. B	
	1. <u>Ultimate pressure reached : a few mbar</u>		
	1.1 Insufficient oil in casing	See B.1	
	1.2 Oil contaminated	See A.5	
	1.3 Oil cold	See B.4	
	1.4 Inlet filter clogged	See B.2	
	1.5 A low-pressure valve has deteriorated	Replace	Parag. 5
	1.6 Part omitted when reassembling	Take apart and reassemble	" 5.5
	1.7 Motor turns in wrong direction	Change two phases	" 3.45
	1.8 Motor underpowered	Check power supply	" 3.45
	2. <u>Ultimate pressure obtained : 10<sup>-2</sup> mbar</u>		
	2.1 O-ring pinched	Replace O-ring	" 5
	2.2 A shaft seal has deteriorated	Replace shaft seal	" 5
	2.3 A high-pressure valve has deteriorated	Replace valve	" 5
	2.4 Lubrication holes clogged	See B.6	
	2.5 Noise control system poorly adjusted	See B.5	
	2.6 Part omitted when reassembling	See C.16	
	3. <u>Accessories</u>		
	3.1 Oil mist eliminator cartridge clogged	Replace cartridge	" 8.2
	3.2 Mechanical pump exhaust installation produces overpressure (> 2 bars)	Check installation	
D. PUMP NOISY	1. Oil contaminated	See 4.5	
	2. Motor underpowered	See C.1.8	
	3. Motor bearings deteriorated	Replace bearings	
	4. Coupling improperly adjusted or deteriorated	Check adjustment	" 5.54
	5. Fan poorly mounted	Check mount	" 5.54
	6. Air inlet tube clogged	Remove and clean	
	7. Noise control system adjusted poorly	See B.5	" 5
	8. Oil pump incorrectly mounted	Remove and remount	" 5.23b
	9. Low-pressure vanes deteriorated	Replace vanes	" + 5.53 5.23b



CHAPTER 7 - TROUBLESHOOTING (end)

PROBLEM	CAUSE	REMEDY	SECTION
E. PUMP TOO HOT	1. Operating at high pressure	Use an oil mist eliminator or oil recycling device Cool the pump with a water cooling device	Parag. 4.3 " 3.44
	2. Oil contaminated	See A.5	" 4.5
	3. Wrong oil	Change oil	" 4.5
	4. Pump located in poorly ventilated location	Check installation	" 3.43b
	5. Ventilation holes clogged	Check installation	" 4.43b
	6. Motor overvoltage	Check voltage, replace motor	" 3.45
	7. Overpressure at exhaust	See C.3.2	
	8. Waterline is not connected	Connect it	
F. HIGH OIL CONSUMPTION	1. Operating at high pressure 2. Pump too hot 3. Leakage at case gasket or shaft seal	See E.1 See E  Replace seals	" 5.4
G. PUMP NOT TIGHT WHEN STOPPED	1. Antisuckback system poorly mounted (diaphragm pinched) 2. O-ring pinched 3. Valve deteriorated 4. Shaft seal deteriorated 5. Oil contaminated	See B.5 See C.2.1 See C.1.5 See C.2.2 See A.5	
H. OIL PRESENCE IN THE EMBASE	1. Oil casing O-ring deteriorated 2. Shaft seal deteriorated	Disassemble oil casing, change O-ring Change it	5.22 5.21 + 5.42
I. OIL LEVELS VARIATION	1. (81) A shaft seal destruction	Change seal (81) A	5.21
	2. <u>Discharge at supressure</u> Oil level from intermediate chamber goes up, casing oil level decreases	Change seal (81) B	5.23
	3. <u>Discharge at low pressure</u> Casing oil level rises, intermediate chamber oil level decreases	Change seal (81) B	5.23

CHAPTER 8 - ACCESSORIES

8.1 - OIL MIST ELIMINATOR

8.11 - INTRODUCTION

a) Description of Product

The oil mist eliminator is designed to separate oil droplets and contaminant particles in the exhaust gases emitted by oil-sealed vacuum pumps.

Since the 2033 H and 2063 H pumps are used to pump expensive or dangerous substances, the hermetic mist eliminator with its helium-tight stainless steel housing guarantees excellent tightness (leakage less than  $5 \times 10^{-7}$  atm cc.sec<sup>-1</sup>).

b) Technical Data

Part No. :	068744
Weight :	4.2 kg
Body :	Stainless steel
Cartridge :	Glass microfibers with epoxy binder
Connection :	NW 40 Pneurop
Location :	Pump body (1 in diagram)
Delivered with :	1 NW 40 quick-connect clamp (No. 083267) 1 centering ring with Viton seal (No. 068230)

c) Dimensions

See figure 2.

8.12 - OPERATING PRINCIPLE

a) Principle

When operating at high pressure, forepumps emit an oil mist entrained by the gas flow. The cartridge in the eliminator filters the gas, trapping the oil by coalescence.

The eliminator captures toxic or harmful pumping products and prevents them from returning to the pump and contaminating it.

The eliminator can also be used for applications involving expensive lubricants.

b) Clogging

The eliminator is provided with a safety valve set to 0.5 bar relative pressure, which prevents overpressure in the oil case if the cartridge clogs.

Avoid solid or sticky deposits that could cause valve to stick to cartridge and malfunction.

c) Oil Sight Glass

If oil is visible in the sight glass, the eliminator must be drained (see Section 8.14 b).

We do not recommend using oil mist eliminators in the following applications : drying, freeze-drying, impregnation of polymerizable resins, debubbling of monomers, etc.

Because the cartridge is flammable, it must not be used when pumping gases such as oxygen and silane, corrosive products, or for microelectronics applications.

8.13 - INSTALLATION AND ASSEMBLY

- a) The oil mist eliminator is mounted on the discharge port of a 2033 H or 2063 H vane pump. The oil level sight glass can be adjusted by changing the position of upper body (1) relative to lower body (2).
- b) On the pump, remove protective cap (23) and elastomer valve (70) (see forepump specifications).
- c) On the eliminator, remove protective cap (15) from outlet (see general drawing).

Connect eliminator intake on (1) to pump discharge port, using centering ring and quick-connect clamp.

Connect eliminator outlet (right side) to a fume exhaust line or to the rest of the vacuum circuit.

Pumping Large Volumes

If the pump is pumping large volumes (greater than 8 m<sup>3</sup> for the 2033 H pump and greater than 10 m<sup>3</sup> for the 2063 H pump) or at high pressure (greater than 60 mbars) for a long time, the manufacturer should be contacted : the pump and oil mist eliminator will require modification (see parag. 4.3).

8.14 - OPERATION AND MAINTENANCE

IMPORTANT NOTE

When the system is disassembled, every precaution must be taken to protect personnel and equipment, depending on the nature and hazard of the pumped gases. Where necessary, we recommend the following precautions :

- . Use gloves and gas mask
- . Make sure room ventilation is adequate and disassemble the oil mist eliminator under an exhaust hood
- . Flush system with dry nitrogen before desassembly
- . Catch residues in an appropriate receptacle

a) Cartridge Saturation

When excess fumes, droplets, or puffs of vapor appear, the cartridge is saturated. If the eliminator is spitting or fuming it needs to be drained (see Section 8.14 b) and the cartridge replaced (see Section 8.14 c).

Spitting and fuming will not be visible if the device is sealed ; check oil sight glass (8).

The time the cartridge takes to saturate will depend on the number of pumping operations, the volume of gas pumped, and the type of oil used.

The cartridge will saturate at an internal pressure of 0.5 bar relative pressure.

b) Draining

When oil is visible in oil sight glass (8), eliminator must be drained.

- . Decontaminate system by flushing with dry nitrogen (if necessary).
- . Drain eliminator by removing plug (10).

c) Disassembly (figure 1)

See general drawing.

- . Drain eliminator (see 8.14 b).

This can be done in two ways :

- . Remove eliminator from pump and disassemble on bench,  
or
- . Remove only lower part (2) of eliminator to change cartridge.

Proceed as follows :

- . Remove screws (13), supporting bottom of eliminator (if disassembled on a bench) or hold lower part (2) in the hand. In either case, make sure spring (5) does not expand suddenly.
- . Separate lower body (2) from upper body (1).
- . Remove O-ring (12), cartridge (4), safety centering device (3), both seals (6), centering device (17), and spring (5).
- . Unscrew plug (10) and remove gasket (11).

If oil sight glass is broken, remove circlip (9), glass disk (8), and gasket (7).

d) Cleaning

- . Never clean filter cartridge. Always replace with a new one
- . After using mineral oil, clean metal parts with solvents such as 1,1,1-trichloroethane or 1,2-dichloroethane (clean when cold).
- . Always replace old gaskets by new ones.

e) Reassembly

- . Place seals (6) on centering devices
- . Assemble (3) and (17)
- . Mount new cartridge on (3)
- . Center spring (5) on (3)
- . Position all the above in lower body (2)
- . Place O-ring (12) in its groove
- . Fasten upper body (1) to body (2) with screws (13)
- . Replace plug (10) and gasket (11).

**8.15 - SPARE PARTS**

Parts that must be replaced each time eliminator is disassembled to change cartridge.

No. in diagram	Quantity	Part	Part No.
4	1	Filter cartridge	068443
6	2	O-ring	082017
11	1	O-ring	082022
12	1	O-ring	079143

Parts that must be changed if oil sight glass breaks :

- 1 O-ring P/N 079327
- 1 circlip P/N 071607
- 1 glass disk P/N 054199

GENERAL DRAWING : figure 1

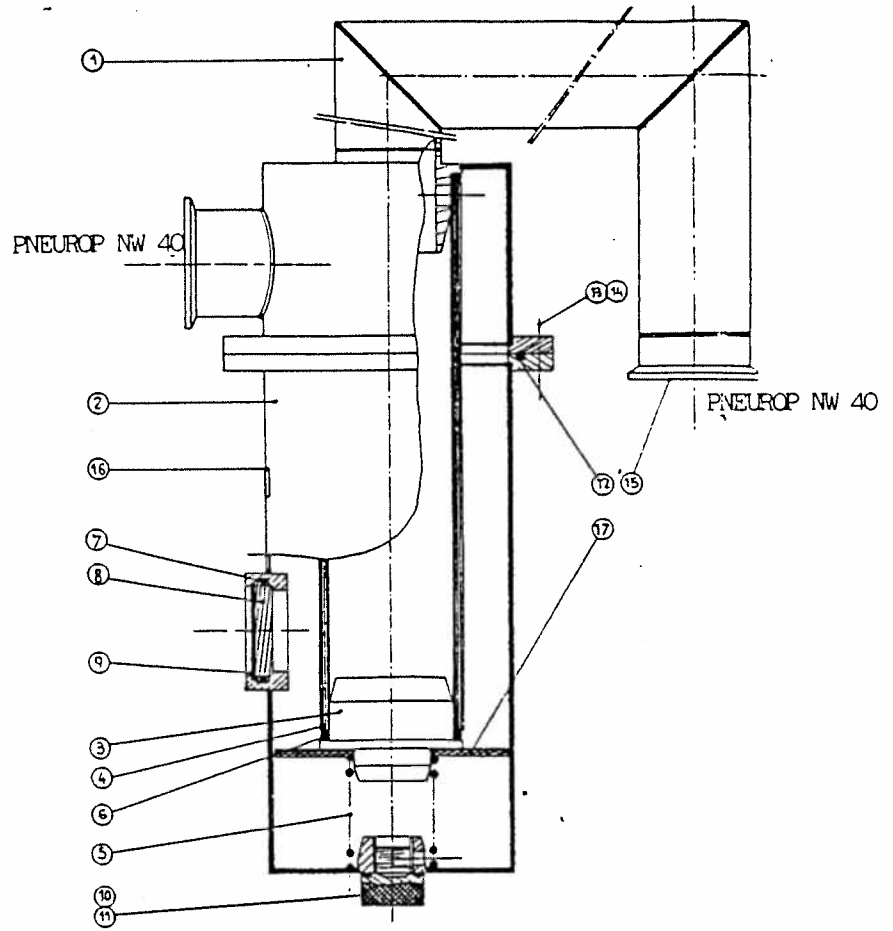

DIMENSIONS : figure 2

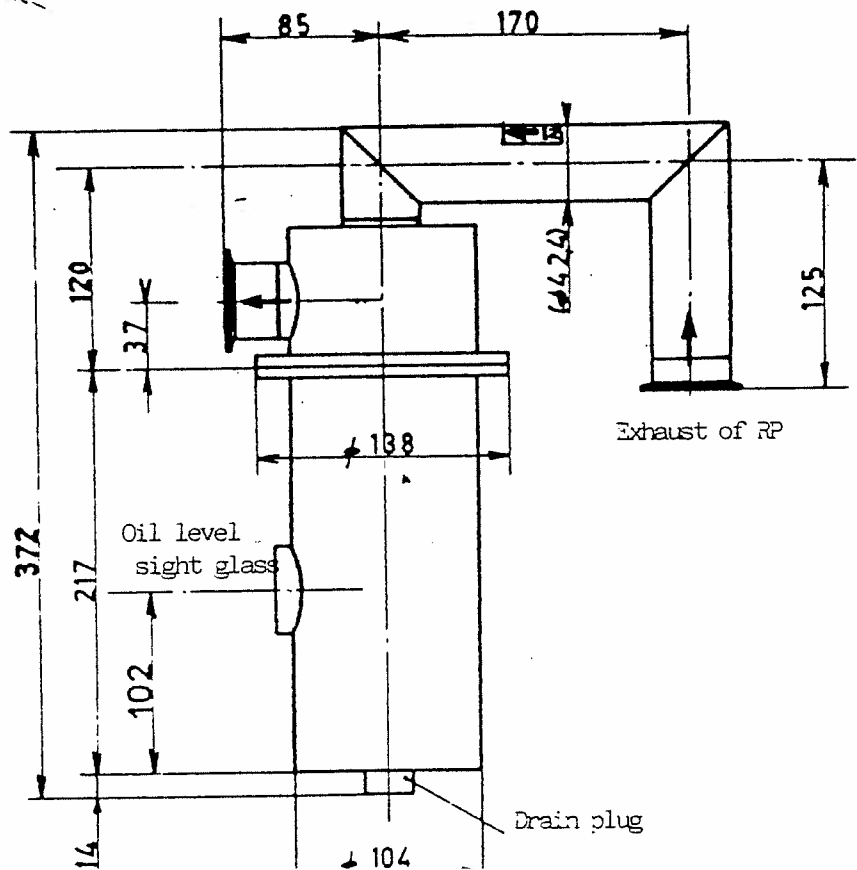

## 8.2 - LIQUID NITROGEN TRAP NW 40

### 8.21 - DESCRIPTION

The liquid nitrogen trap is mounted on the intake of a mechanical roughing pumps  $33/63 \text{ m}^3\cdot\text{h}^{-1}$ . Made entirely of stainless steel, it is equipped with a purging system in its lower part.

### 8.22 - CHARACTERISTICS AND PART NUMBER

Dimensions : See figure 1.  
Connections : NW 40 Pneurop.  
Weight : 3 kg.  
Liquid nitrogen capacity : 1 liter.  
Conductance at  $10^{-1}$  mbar :  $55 \text{ l}\cdot\text{s}^{-1}$ .  
Autonomy ( $P < 10^{-4}$  mbar) : 15 hours  
Pumping speed (water vapor) :  $10 \text{ l}\cdot\text{s}^{-1}$ .  
Part number : 786537.

### 8.23 - OPERATING PRINCIPLE

The liquid nitrogen trap is used for cryogenic pumping of vapors and gases with condensation temperatures above 77 K (temperature of liquid nitrogen). It therefore increases pumping speed for these vapors of gases.

It protects the pump against condensable vapors that could be entrained during pumping.

It prevents oil from being drawn into the system by back diffusion.



## 8.24 - INSTALLATION

- a) Accessories whose tightness and materials are compatible with the pumped gases and the required safety conditions must be used upstream and downstream of the trap.
- b) Read parag. 8.25 and 8.26 before installing liquid nitrogen trap.
- c) The trap openings are provided with ISO NW 40 flanges for Pneurop type quick connect clamps, allowing various fittings to be connected (see diagram 5).
- d) See figure 2.

## 8.25 - OPERATION

**Important note :** In general, the trap should not be used at pressures above some mbar, because it becomes contaminated very rapidly under these conditions.

A system with a by-pass valve should be used, or the trap should not be filled until the pressure is sufficiently low ( $5 \cdot 10^{-3}$  mbar).

### a) **Filling with liquid nitrogen**

- Lower pressure in trap until it is nearly  $5 \cdot 10^{-3}$  mbar.
- Fill trap with liquid nitrogen.
- Use a funnel or filling tube less than 14 mm in diameter.
- Let trap cool, then top up a few minutes later.

### b) **Time between recharges**

The time between recharges depends on the following :

- Frequency of use.
- Operating pressure (operation at high pressure causes more rapid contamination).
- Nature of pumped gases (quantity of condensable vapor).

From pumping on a clean chamber pressure near  $10^{-4}$  to  $10^{-3}$  mbar the trap can be used for 12 to 15 hours between recharges.

## 8.26 - MAINTENANCE

**IMPORTANT :** each time the system is dismantled, take all necessary precautions to ensure safety and protection of personal against possible toxicity, corrosion, and radioactivity of residues.  
Proceed as follows :

1. Purge system with dry nitrogen before working on it.
2. Wear gloves, goggles and mask.
3. Ventilate area thoroughly and disassemble parts under a fume hood.
4. Collect residues in appropriate containers.
5. Do not simply discard residues, and have them destroyed by a competent organization if necessary.

**Important note : do not do the following when using a trap :**

1. **Close trap under vacuum when cold, and allow to warm up** : If the pumped products are in the gase phase at room temperature, over-pressure will be created in the trap which depends of the saturated pressure from pumped products.
2. **Regenerate trap by allowing it to warm up and then pumping down using a mechanical pump.**

The pump and the oil in it will be contaminated as a result of a large quantity of products havig to be trapped in a very short time.

**a) Flushing Nitrogen Trap**

When the products being pumped are liquid at room temperature, the trap can be flushed.

**Note** : Flushing opens a contaminated pumping system to the environment.

Take all precautions necessary to ensure personnel safety ; see parag. 8.26.

**Procedure :**

With trap cold, flush system with dry nitrogen.

Isolate trap by closing isolation valves.

Open purge and allow trap to warm up.

The condensed products will liquefy and will be evacuated through the purge. When operation is complete, close purge and pump down trap again.

**b) Cleaning**

With trap cold, break vacuum with dry nitrogen.

Isolate trap by closing isolation valves.

Disconnect trap from system.

Open purge under a fume hood and allow trap to warm up.

The condensed products will liquefy. Purge the trap.

Then remove the cover together with the tube by removing the four bolts.

**After using mineral oil**, dip body and tube of trap in a solvent such as 1.1.1. trichloroethane or 1.2. dichloroethane (cold cleaning).

Freon 113 \* can also be used for ordinary cold cleaning.

Rinse trap with alcohol and dry thoroughly. Reclose purge of NW 40 trap and replace tube on body (handle carefully). Replace trap in system. Pump down again to degas trap.

\* Registered Trademark of DU PONT DE NEMOURS.

c) Spare parts

DESCRIPTION	P/N
Drain O-ring	82100
Cover O-ring	82153

Figure 1 : Dimensions

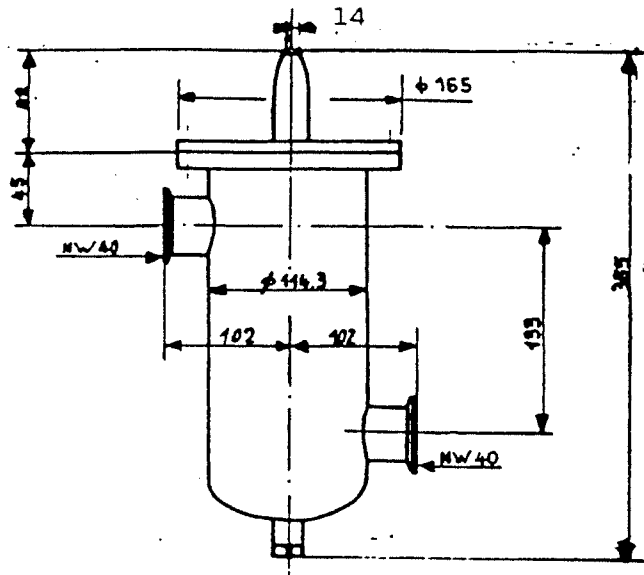
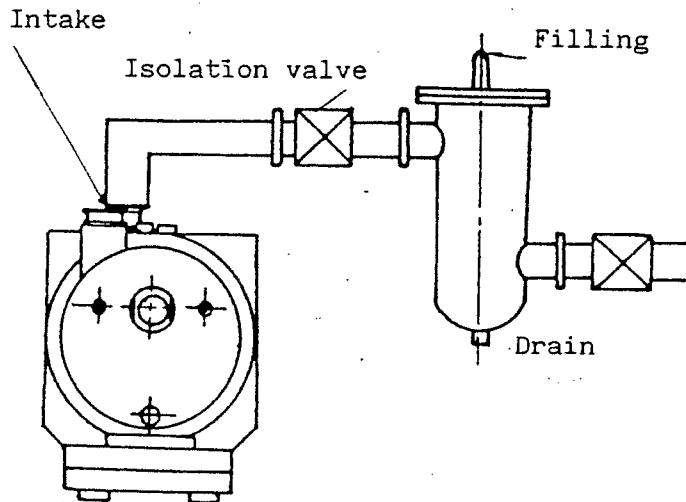
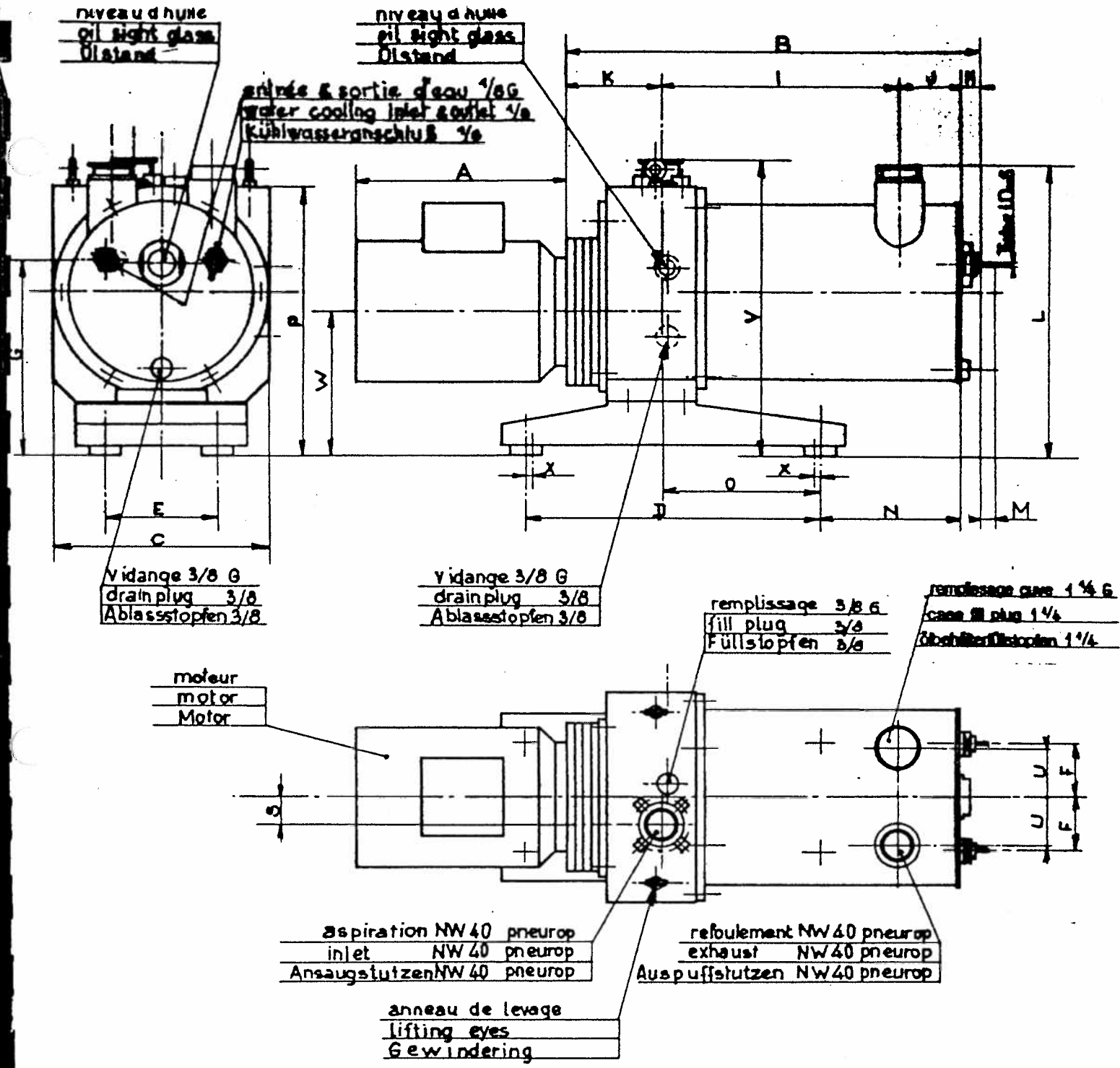

Figure 2 : Assembly





	A	B	C	D	E	F	G	H	I	J	K	L	M	N	O	P	Q	R	S	T	U	V	W	X
2033-H MIN 225 MAX 262	518,5	269	375	140	69,5	245,5	22	295	80	121,5	370	35	177	198	342	/	/	35	/	62	376	182	0	
2063-H MIN 278 MAX 286	586	293	459	190	58,5	262,5	22	349	78	137	386	35	206	221	363	/	/	40	/	62	397	198	5	

ENCOMBREMENTS  
DIMENSIONAL DATA  
ABMESSUNGEN — 2033.H — 2063.H  
FIGURE 1 / DIAGRAM 1 / ABBILDUNG 1

Procédé de démontage des joints à lèvres  
 Removal of lip seals  
 Lipdichtungen Demontage



Manchon protecteur  
 Protective sleeve  
 Schutzhülse

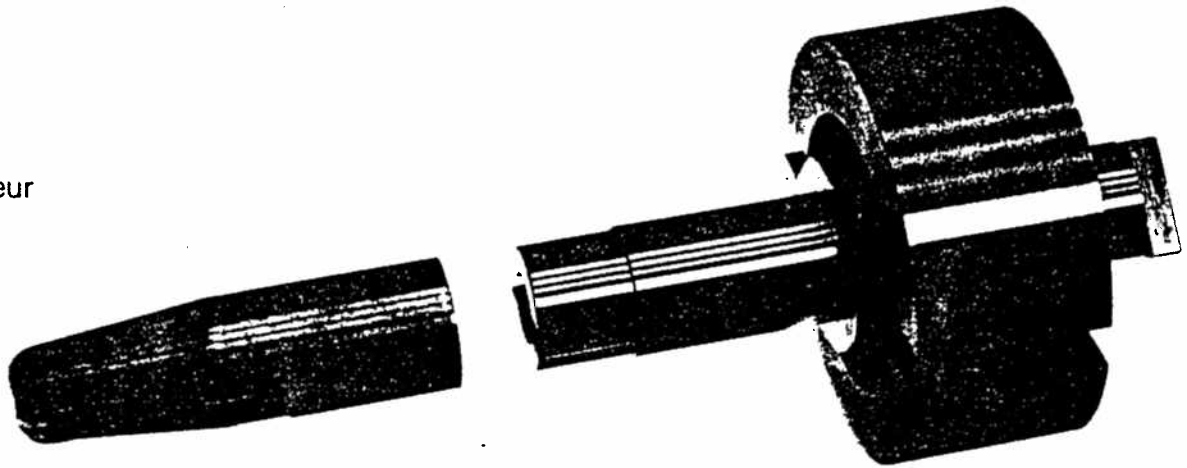

Mandrins de montage des joints à lèvres  
 Tools for installing lip seals  
 Montagedorn

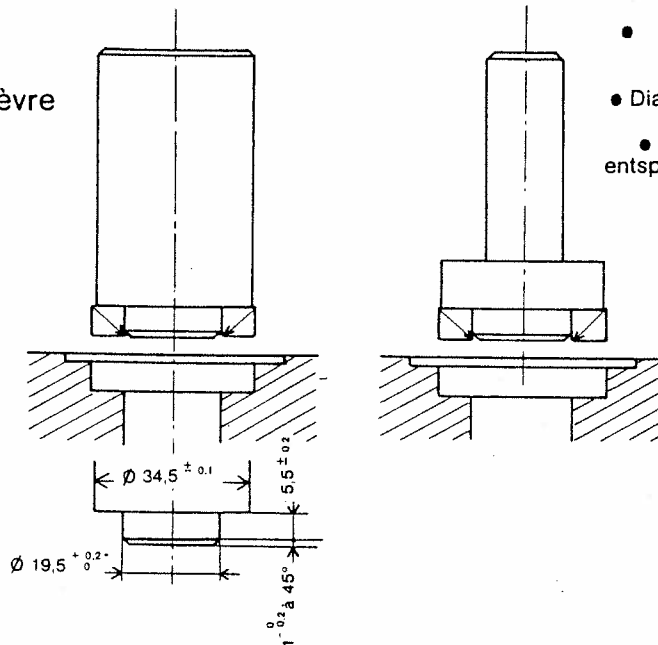

- adapté au mandrin de la presse ou de la perceuse
- Diam. adapted to press or drill chuck
- Dorndurchmesser entsprechend Presse oder Bohrmaschine

# DIAGRAM 03 ELECTRIC MOTORS

## CHARACTERISTICS, CONNECTIONS, PROTECTIONS

The following electrical information is intended as a guide : local electrical codes ; NEMA specifications and procedures must be adhered to for all electrical devices.

Use of an electrical protective device on the pump motor protects :  
 - The motor : in the event of overvoltage or pump seizure, the resulting excess current can destroy the motor windings and possibly the starter.

- The pump : in the event of a locked pump rotor due to contaminated oil, presence of particles, or non-lubrication, serious damage may occur.

### Type of protection

NEVER USE FUSES TO PROTECT A THREE-PHASE MOTOR UNLESS ALSO FITTED WITH A DIFFERENTIAL SYSTEM : Differential thermal circuit interrupters or motor starter must be used ; the mechanism includes a quick-opening switch controlled by a bimetallic strip, which is activated by excessive current draw.

### Choice of size

Two operating modes must be considered : starting and continuous duty.

### Starting :

During starting, the torque furnished by the motor to start the pump is considerable :

- In a **single-phase motor** : use of the auxiliary phase and a starting current which can reach 5 to 7 times the rated current ;
- In a **three-phase motor** : excess current 2 to 2.5 times the rated current.

### Starting in a Cold Environment (less than 18°C/65°F)

In certain cases, when the pump has to start in a cold environment, or with slightly contaminated or viscous oil, the current after starting can remain high until the pump oil heats up (10 to 20 minutes) :

- **single-phase motor** : twice the rated current.
- **three-phase motor** : 1.5 times the rated current.

These values are given as examples, and can vary according to the type of pump and oil used.

### Continuous Duty

This is the normal pump operating mode after about 1 hour of operation. The current is then slightly less than the rated current of the motor.

As a consequence, dual integrated protection should be used : one for continuous duty (which will also protect the pump for starts under normal conditions — oil clean, temperature above 18°C, etc.), and one for start conditions.

When starting : the time the pump takes to get up to full speed should not exceed 15 seconds.

### Pumps on 50 Hz (European pumps)

MECHANICAL PUMPS	MOTOR	POWER	VOLTAGE	SIZE
2002A - 2002 B	Single phase	0,170 kW	220 V	2 A
1004 A - 2004 A - 2008 A 1004 AC - 2008 AC	Single phase	0,375 kW	220 V	4 A
1012A - 2012 A 2012 AC - 2012 CP1 - 2012 AH	Single phase	0,375 kW	220 V	6 A
1004 A - 2004 A 1004 AC	Three phase	0,375 kW	220 V 380 V	2 A 1,2 A
2008 A - 1012 A - 2012 A - 2012 AH 2008 AC - 2012 AC - 2012 CP1	Three phase	0,375 kW	220 V 380 V	4 A 2 A
2020 A - 2020 AC - 2020 CP1	Single phase	0,55 kW	220 V	6 A
	Three phase	0,55 kW	220 V 380 V	4 A 2 A
2033 C 2033 CP1 - 2033 H	Three phase	1,1 kW	220 V 360 V	6 A 4 A
2063 - 2063 C 2063 CP1 - 2063 H	Three phase	2,2 kW	220 V	10 A
			380 V	6 A

### Pumps for 60 Hz (US Pumps)

MECHANICAL PUMP	MOTOR	POWER	VOLTAGE	SIZE
2002 A 2002 B	Single phase 60 Hz	200 W	120 V 220 V	4 A 2 A
1004 A - 1004 AC 1012 A 2008 A - 2008 AC	Single phase 50 Hz	0,375 kW	100 V	10 A
	Single phase 60 Hz	0,550 kW	100 V	10 A
	Single phase 60 Hz	0,245 kW	115 V	8 A
2012 AH 2004 A 2012 A 2012 AC 2012 CP1	Three phase 50 Hz	0,375 kW	200 V	4 A
	Three phase 60 Hz	0,245 kW	200 V	4 A
	Three phase 60 Hz	0,375 kW	220 V	4 A
	Three phase 60 Hz	0,550 kW	460 V	4 A
2020 A 2020 AC 2020 CP1	Single phase 50 Hz	0,550 kW	100 V	10 A
	Single phase 60 Hz	0,660 kW	100 V	10 A
	Single phase 60 Hz	0,660 kW	115 V	8 A
2033 2033 C 2033 CP1 - 2033 H	Three phase 60 Hz	1,1 kW	200 V	6 A
	Three phase 60 Hz	1,1 kW	220 V	6 A
	Three phase 60 Hz	1,1 kW	460 V	4 A
2063 2063 C 2063 CP1 2063 H	Three phase 50 Hz	2,2 kW	200 V	10 A
	Three phase 60 Hz	2,2 kW	200 V	10 A
	Three phase 60 Hz	2,2 kW	220 V	10 A
	Three phase 60 Hz	2,2 kW	460 V	6 A

### Electrical Connections for Three-Phase Motors

The pumps can be equipped with different brands of motors, the numbered connections are for your information. If there is any doubt, only the specification label in the electrical box will supply the correct information.

#### 1) CEI Terminal Box (Europe) :

##### LOW-VOLTAGE CONNECTIONS

200 or 220 V - 50 or 60 Hz

##### Delta connection

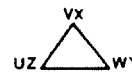
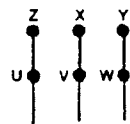

##### HIGH-VOLTAGE CONNECTIONS

380 V - 50 Hz or 460 V - 60 Hz

##### Star connection

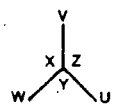
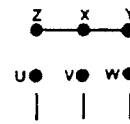

#### Connection examples.

#### 2) NEMA Terminal Box (USA) (9 wires) :

##### LOW-VOLTAGE CONNECTIONS

200 or 220 V - 60 Hz

##### Parallel connection

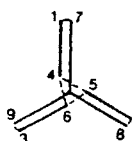
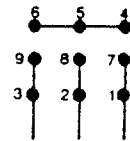

##### HIGH-VOLTAGE CONNECTIONS

460 V - 60 Hz

##### Serie connection

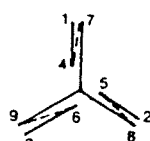
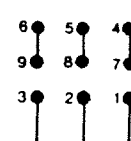

#### 3) NEMA Terminal Box (USA) (12 wires) :

##### LOW-VOLTAGE CONNECTIONS

220 or 240 V - 50 or 60 Hz

##### Parallel connection

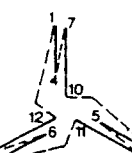
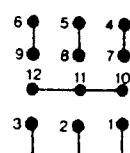

##### HIGH-VOLTAGE CONNECTIONS

380 or 460 V - 50 or 60 Hz

##### Serie connection

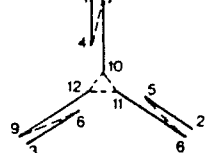
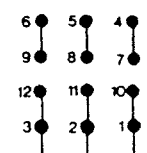

ACCESSOIRES DE RACCORDEMENT ET ELEMENTS DE CANALISATION	CONNECTINGS ACCESSORIES AND VACUUM FITTINGS	ANSCHLUSSFLANSCHEN (UN) VERBINDUNGSELEMENTE	RACCORDEMENT DN 40 Ref. NW 40 CONNECTION P/N NW 40 FLANSCH Best Nr.
Anneaux de centrage - inox/Perbunan - inox/Viton	Centering rings - stainless steel/Buna - stainless steel/Viton	Zentrierringe - Edelstahl/Perbunan - Edelstahl/Viton	Pompes standards Standard pumps Standard-Pumpen  68194  68230
Colliers de serrage	Quick connect clamp	Spannringe	83267  83267
Tuyaux plastique armé longueur 1 m	Reinforced plastic hoses 1 m length	Plastikschläuche Länge 1 m	68272
Tuyaux flexibles inox longueur 0,5 m longueur 1 m	Flexible stainless steel hoses 0,5 m length 1 m length	Edelstahl-Wellschläuche Länge 0,5 m Länge 1 m	68374 68375
Embouts lisse - Macrovac - Inox.	Long nipples - Macrovac - stainless steel	Anschweisflansche - PVC - Edelstahl	68592  68217
Coudes égaux - Macrovac - Inox.	Symmetrical elbows - Macrovac - stainless steel	Winkelstücke 90° - PVC - Edelstahl	68587  68238
Tés égaux - Macrovac - Inox.	Symmetrical tees - Macrovac - stainless steel	T - Stücke - PVC - Edelstahl	68588  68564
Obtrateurs - Macrovac - Inox.	Blank-off flanges - Macrovac - stainless steel	Blindflansche - PVC - Edelstahl	68595  68197

PLANCHE 5 / DIAGRAM 5 / ABBILDUNG 5

TABLEAU DE SÉLECTION DES POMPES ET ACCESSOIRES EN FONCTION DE L'APPLICATION  PUMPEN UND ZUBEHÖR NACH ANWENDUNGSBEREICH	POMPES PUMPEN				HUILES ÖL	ACCESSOIRES ZUBEHÖR										TABLE OF PUMPS AND ACCESSORIES RECOMMENDED FOR DIFFERENT APPLICATIONS
	Standard	Chimie - Chemie	Hermétique - Hermetik	Chimie-Plasma Chemie-Plasma	Minérale - Mineralöl	ALCATEL 113 (PTFE)	Séparateur de brouillard Dübelabscheider	Piège à sorption Sorptionstafel	Piège à azote liquide Flüssig-Stickstoff-Falle	Filtre à huile (O) Ölfiter (O)	Filtre à huile (DE) Ölfiter (DE)	Lest d'air automatique Automatischer Gasballast	Purge d'azote Neutral gasreinigung	Condenseur Kondensator	Filtre à poussières Staubfilter	
Cryogénie Kryotechnik	○		×		×		×	○								Cryogenics
Récupération de gaz précieux Rückgewinnung teurer Gase			×		○	○	×	○				▲				Noble gas recovery
Pompage de l'oxygène Pumpen von Sauerstoff	×	○			▲	×	○	○				○				Oxygen pumping
Séchage Trocknung	×				×		◇		○	○		×		×	○	Drying
Lyophilisation alimentaire Gefriertrocknung	×	○			×		◇					×				Freeze drying, food
Lyophilisation biologique Biolog. Gefriertrocknung		×		×	×	○	◇			○	×					Freeze drying, biology
Dépot en phase gazeuse (CVD) Beschichten in Gasphase		×			×	○	◇		▲	×		○	×		◇	CVD
Implantations d'ions Ionimplantation		×		×	×	○	○	○			×					Ion implantation
Gravure sèche Trockenätzung		×		×	○	×	◇	○	○	×	○		×			Dry etching
Evaporation sous vide Vakuumverdampfung	×				×		○	×	○	○		×			○	Vacuum evaporation
Érosion cathodique Ionenstrahlätzung	×	○			×		×	×	○							Cathode sputtering
Dépot par MBE Beschichtung mit MBE	×				×		×	×					×			Deposition (MBE)
Pompage de réservoir Reserve-Pumpsystem	×				×		×	×	○							Reservoir pumping
Imprégnation sous vide Vakuumimprägnierung	×				×		◇	○		○		×	×		◇	Vacuum impregnation
Industrie frigorifique Kühlindustrie	×				×		×		○							Refrigeration industry
Fabrication de lampes Lampenfabrikation	×		○		×		×	○							○	Bulb manufacture
Pompage de tube cathodique Evakuierung von Katodenstrahlröhren	×				×		×									Cathode tube pumping
Distillation moléculaire Molekulardestillation		×			○	○	◇				○	○				Molecular distillation
Emballage sous vide Vakuumverpackung	×				×		×					○			×	Vacuum packaging
Contrôle d'étanchéité Lecksuche	×				×		×	○	○			○			○	Leak detection
× Conseillé - Empfohlen ○ Possible - Möglich ◇ Non recommandé - Nicht empfohlen ▲ Dangereux - Gefährlich	Standard	Chemical	Hermetic	Chemical-Plasma	Mineral	Alcatel 113 (PTFE)	Oil mist eliminator	Sorption trap	Liquid nitrogen trap	Oil filtration (O filter)	Oil neutralization (DE filter)	Remote controlled gas ballast	Neutral Gas supply	Condenser	Dust filters	× Recommended ○ Possible ◇ Not recommended ▲ Dangerous
	PUMP				OIL	ACCESSORY										

ALCATEL vous fera profiter de son expérience en vous conseillant à la fois sur le choix de la pompe et sur celui des accessoires répondant aux exigences de votre application.  
 ALCATEL steht Ihnen zur Beratung beim Kauf von Pumpen und Zubehör mit seiner Erfahrung zur Verfügung.  
 ALCATEL'S experience may assist you in proper selection of pumps and accessories best suited for your application.



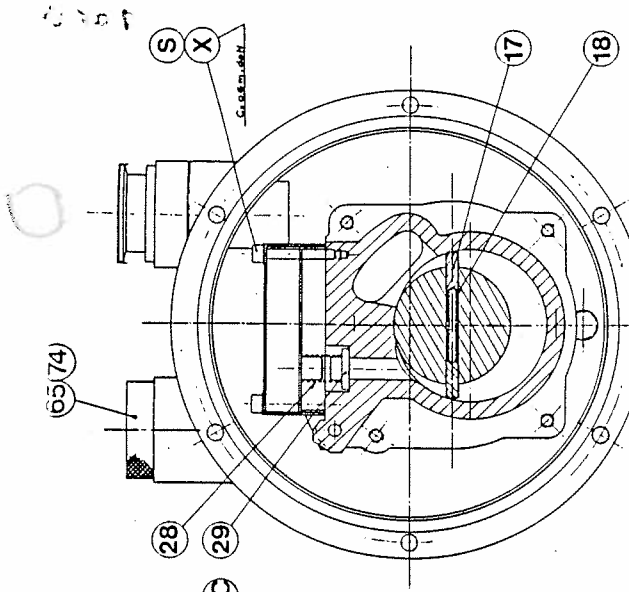

Code A  
2033H 166 mm  
2063H 23.3 mm

23 DEC 1986

